

**ANGEBOT: EREL05**

**KUNDE:**

**LIEFERORT:** 9871 SEEBODEN. LIEFERUNG GEGEN AUFPREIS

**GARANTIE:** 1 Jahr ab den Zeitpunkt der Auslieferung

**ZAHLUNGSBEDINGUNGEN:** 50% Anzahlung. 50% vor Auslieferung

**LIEFERZEIT:** Nach Vereinbarung. Regelfall ca. 3-4 Monate.

BESCHREIBUNG	PREIS
<p><b>Elektrischer Radlader EREL05</b> mit Standardschaufel, Schnellwechsler, wartungsfreien Batterien 120Ah, elektrischem Joystick, LED-Arbeitsscheinwerfern, 6.00-12-Reifen, mit Überrollbügel.</p>	<p><b>€ 10.750,-</b> <i>Inkl. € 12.900,-</i></p>



Optional			
<b>150Ah Batterie</b>	<b>+ € 408,-</b> <i>Inkl. € 490,-</i>	<b>Farbe</b>	<b>wählbar (RAL)</b>
<b>Dach</b>	<b>+ € 158,-</b> <i>Inkl. € 190,-</i>	<b>23*8.5-12 Reifen +14cm Gesamtbreite</b>	<b>+ € 242,-</b> <i>Inkl. € 290,-</i>

<b>Technische Details</b> <i>Technical parameters</i>	
<b>Nennlast</b> <i>Rated Load</i>	500kg
<b>Nennkapazität der Schaufel</b> <i>Bucket rated capacity</i>	0,2m <sup>3</sup>
<b>Schütthöhe bei 45°</b> <i>Dumping height @45°</i>	1350mm
<b>Hubhöhe</b> <i>Lifting heigh</i>	2100mm
<b>Dumping Reichweite</b> <i>Dumping reach</i>	450mm
<b>Max. Hubgewicht</b> <i>Max. Lifting Weight</i>	500kg
<b>Max. Ausgrabungskraft</b> <i>Max. Excavation Force</i>	8kN
<b>Max. Steigfähigkeit</b> <i>Max. grade Ability</i>	15°
<b>Max. Wendewinkel</b> <i>Max. turning Angel</i>	28° ± 1
<b>Hinterachsswinggrad</b> <i>Rear Axle Swing Degree</i>	3
<b>Abmessungen &amp; Gewicht</b> <i>Dimensions &amp; Weight:</i>	
<b>Gesamtlänge Schaufel in Bodenposition</b> <i>Overall lenght Bucket in ground position</i>	2900mm
<b>Schauflebreite (insgesamt)</b> <i>Bucket width (overall)</i>	945mm
<b>Fahrzeugbreite</b> <i>Vehichle width</i>	920mm
<b>Fahrzeugbreite mit 23*8.5-12 Reifen</b> <i>Vehichle width with 23*8.5-12 Tyre</i>	1060mm
<b>Gesamthöhe</b> <i>Overall height</i>	2070mm
<b>Radstand</b> <i>Wheel Base</i>	1385mm
<b>Min. Bodenfreiheit</b> <i>Min ground clearance</i>	300mm
<b>Nettogewicht</b> <i>Net weight</i>	900kg
<b>Batterie</b> <i>Battery</i>	
<b>Batteriemodell Nr.</b> <i>Battery modell No.</i>	6-EVF-100Ah <i>or 120Ah or 150Ah</i>
<b>Nennkapazität</b> <i>Rated capacity</i>	(3hr) 100Ah
<b>Anzahl der Batterien</b> <i>No. of batteries</i>	5
<b>Nennspannung</b> <i>Rated voltage</i>	60V

<b>Arbeitszeit</b> <i>Working hours</i>	4h
<b>Hydrauliksystem</b> <i>Hydraulic System</i>	
<b>Motortype</b> <i>Motortype</i>	HL-60
<b>Spannung</b> <i>Voltage</i>	60V
<b>Leistung</b> <i>Power</i>	1200W
<b>Verschiebung</b> <i>Displacement</i>	14mL/R
<b>Öl Kapazität</b> <i>Oil Capacity</i>	
<b>Hydrauliköltank</b> <i>Hydraulic Oil</i>	11L
<b>Bremsflüssigkeit</b> <i>Brake Fluid</i>	0,8L
<b>Bremssystem</b> <i>Braking System</i>	
<b>Betriebsbremse</b> <i>Service Brake</i>	Trommelbremse <i>Drum Brake</i>
<b>Bremstrommel</b> <i>Brake Drum</i>	200m
<b>Feststellbremse</b> <i>Parking break</i>	Trommelbremse <i>Drum Brake</i>
<b>Verteilerventil</b> <i>Distribution valve</i>	Model DL10
<b>Dumpingzylinderbohrung</b> <i>Dumping Cylinder bore</i>	Ø 50mm
<b>Hubzylinderbohrung</b> <i>Lifting Cylinder bore</i>	Ø 50mm
<b>Steuersystem</b> <i>Steering System</i>	
<b>Vollhydraulisches System</b> <i>Full Hydraulic Steering system</i>	
<b>Externe Zahnradpumpe</b> <i>External gear pump</i>	1pc
<b>Lenkzylinder Bohrung</b> <i>Steering cylinder bore</i>	50mm
<b>Systemdruck</b> <i>System pressure</i>	160bar <i>16mpa</i>
<b>Reifen Type</b> <i>Tyres type</i>	6.00-12
<b>Arbeitsdruck</b> <i>Working pressure</i>	0,25bar <i>0.025mpa</i>
<b>Anzahl der Reifen</b> <i>Qty Tyres</i>	4

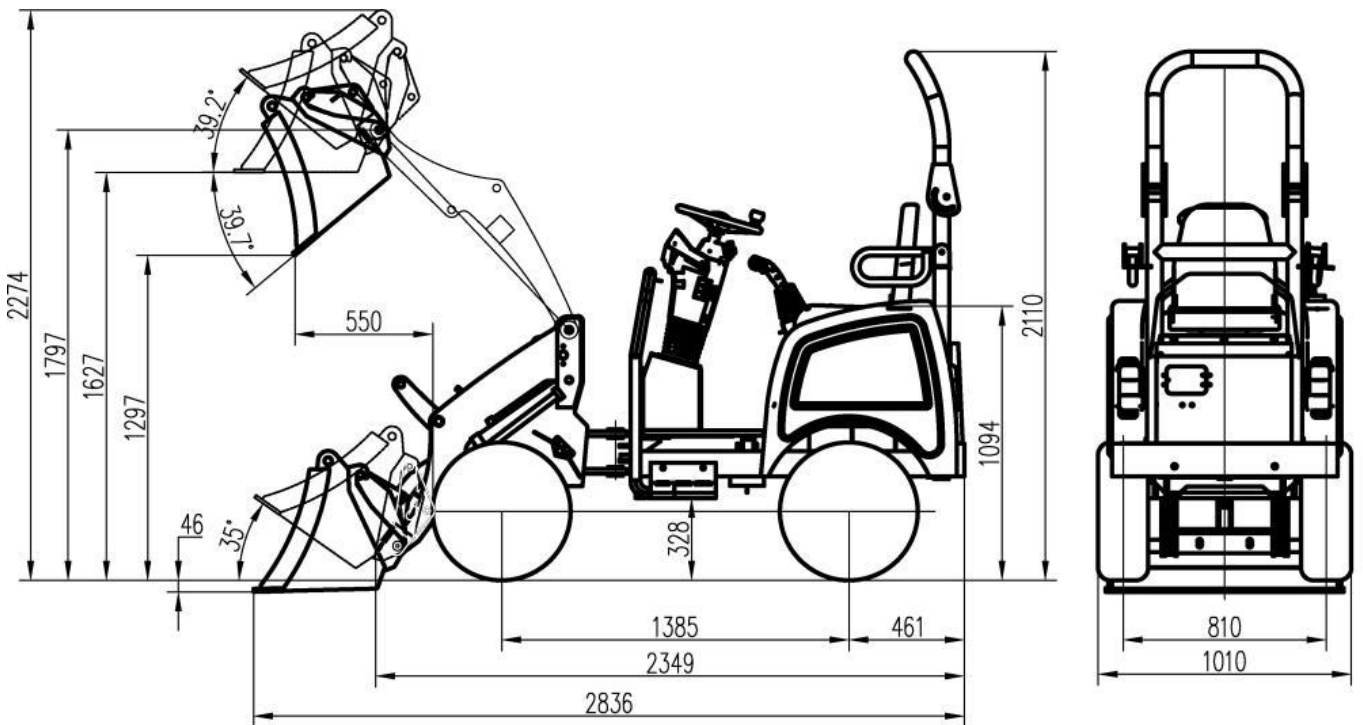
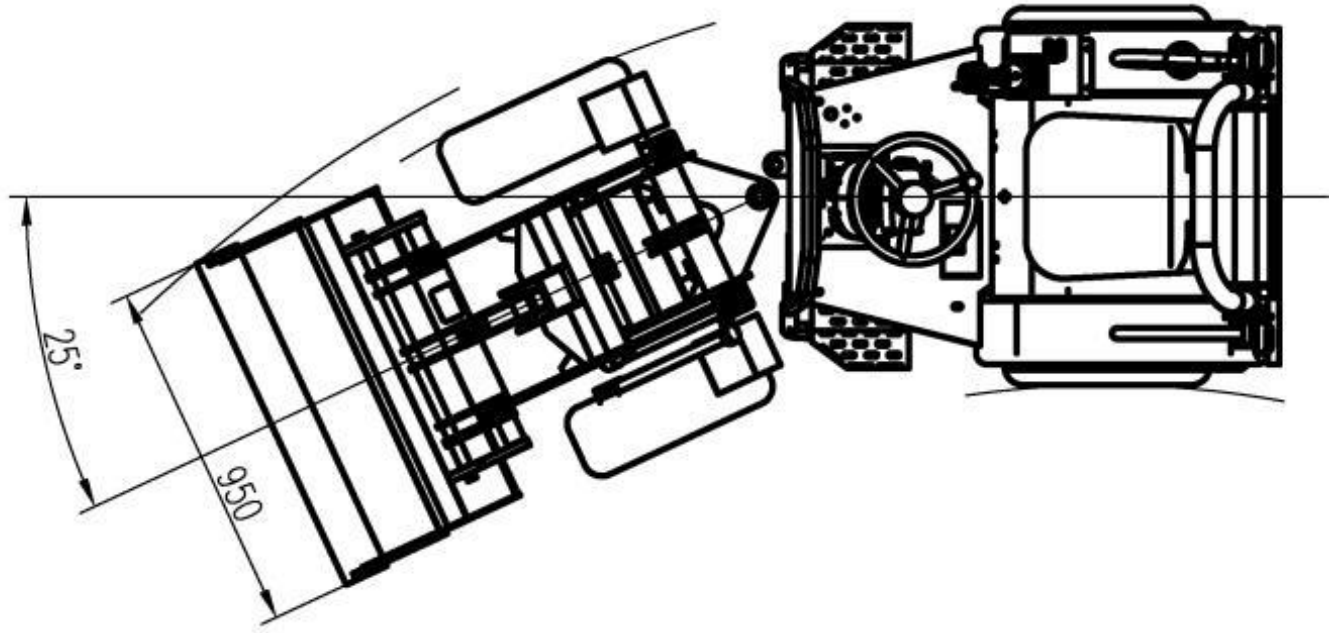

<b>Zubehör</b>			
			
<b>Standard Schaufel</b> <i>Standard Bucket</i> <i>t*b*h= 560*950*530 / 0,14m³</i>	<b>inkl.</b>	<b>Palettengabeln</b> <i>Pallet forks</i> <i>t*b*t= 170*800*460</i>	<b>€ 825,-</b> <i>Inkl. € 990,-</i>
			
<b>4-in-1-Schaufel</b> <i>4 in 1 bucket</i> <i>t*b*h= 700*1000*500 / 0,11m³</i>	<b>€ 1325,-</b> <i>Inkl. € 1590,-</i>	<b>Schneeschaufel 1,2m</b> <i>Snow Bucket</i> <i>t*b*h= 800*1205*640</i>	<b>€ 658,-</b> <i>Inkl. € 790,-</i>
			
<b>Steinschaufel</b> <i>Rock Bucket</i> <i>t*b*h= 620*1100*555</i>	<b>€ 1075,-</b> <i>Inkl. € 1290,-</i>	<b>Bagger</b> <i>Digger (digging depth 1280mm)</i> <i>t*b*h= 1620*1000*1620 / 0,01m³</i>	<b>€ 992,-</b> <i>Inkl. € 1190,-</i>
			
<b>Elektrischer Mäher</b> <i>Electric Mower</i> <i>t*b*bh= 1400*1160*650</i>	<b>€ 1992,-</b> <i>Inkl. € 2390,-</i>	<b>Greiferschaufel</b> <i>Grapple Bucket</i> <i>t*b*h= 750*900*550</i>	<b>€ 1075,-</b> <i>Inkl. € 1290,-</i>

			
<p><b>Heugabeln mit Einzelgabel</b> Hay Forks with single fork t*b*h= 1000*900*600</p>	<p><b>€ 408,-</b> Inkl. € 490,-</p>	<p><b>Grieffabeln</b> Grapple Forks t*b*h= 720*1100*685</p>	<p><b>€ 1242,-</b> Inkl. € 1490,-</p>
			
<p><b>Mistgabeln</b> Manure Forks t*b*h=1030*1000*650</p>	<p><b>€ n.A.-</b> Inkl. € n.A.-</p>	<p><b>Schneeräumschild</b> Snow Blade t*b*h= 850*1300*500</p>	<p><b>€ 1158,-</b> Inkl. € 1390,-</p>
			
<p><b>(400 mm) Schnecke</b> (400mm) Auger Rod ø200*700</p>	<p><b>€ 1408,-</b> Inkl. € 1600,-</p>	<p><b>Ballengreifer</b> Bale Grab t*b*h=1230*1100*585</p>	<p><b>€ n.A.-</b> Inkl. € n.A.-</p>
			
<p><b>Europäische Greifergabeln</b> European Grapple Forks</p>	<p><b>€ n.A.-</b> Inkl. € n.A.-</p>		



**Schneeketten**  
Tyre Chain

€ 158,-  
Inkl. € 190,-

Es handelt sich um Symbolfotos. Preisänderungen und Tippfehler vorbehalten.

**Bilder:**

